

# Introduction to **Specifying HVLS Fans**

by: **MacroAir**  
engineers of air™



High Volume, Low Speed (HVLS) fans are widely used in commercial settings due to their superior performance to provide comfort, energy savings, and versatility. When compared to traditional high-speed fans, HVLS fans offer the architect and engineer greater control over the design and implementation of air circulation strategies in large, high ceiling environments.

In this guide we will discuss:

1. Efficient temperature control
2. Factors that affect air displacement
3. HVLS project solutions
4. Selecting an HVLS fan

After reading this guide, you should understand the benefits of HVLS fans and what factors to consider when specifying an HVLS fan into your project.

## Why Commercial Facilities need HVLS Fans

Architects and engineers are faced with the challenge of finding an energy efficient temperature control solution. Creating an environment that is comfortable for employees and doesn't overwhelm the utility budget can prove challenging.

There are many factors that influence the climate in large facilities:

- **High ceilings:** contribute to the buildup of heat layers
- **Open bays:** allow infiltration of outdoor air
- **Obstructions:** act as air flow barriers preventing air circulation
- **Heat pockets:** stagnant climate zones or temperature pockets
- **Seasonal temperature swings, high humidity**

## Cooling

According to OSHA, a comfortable workplace temperature ranges from 68°F to 76°F. Uncomfortably warm temperatures can lead to a decrease in worker output and an increase in errors. HVLS fans can help promote productivity by moving a large column of air, creating a cooling breeze throughout the entire work area. It only costs about a dollar a day to run an efficient HVLS fan, and it decreases the perceived temperature by 8°F!

## Heat Stratification

Without air movement, buildings with high ceilings experience heat stratification. This means that temperature layers develop with cooler air at floor level and warmer air at the ceiling. Temperature increases 0.5°F each foot, so the temperature difference between the floor and rafters of a 20-foot building would be about 10 degrees.

During the winter, HVLS fans can run in reverse to de-stratify and re-distribute the air. This is particularly effective if you are designing an air circulation strategy that includes an HVAC system. Pairing an HVAC system with HVLS fans will yield a minimum of 20% savings on heating costs by increasing warm air at ground level and reducing heat loss through the roof. This simple, yet highly effective solution makes HVLS fans a year-round climate control solution.

Initially the ceiling temperature in the room below is 10° warmer than ground level. As the HVLS fan runs in reverse, it easily addresses the issue of heat layers by de-stratifying the air.

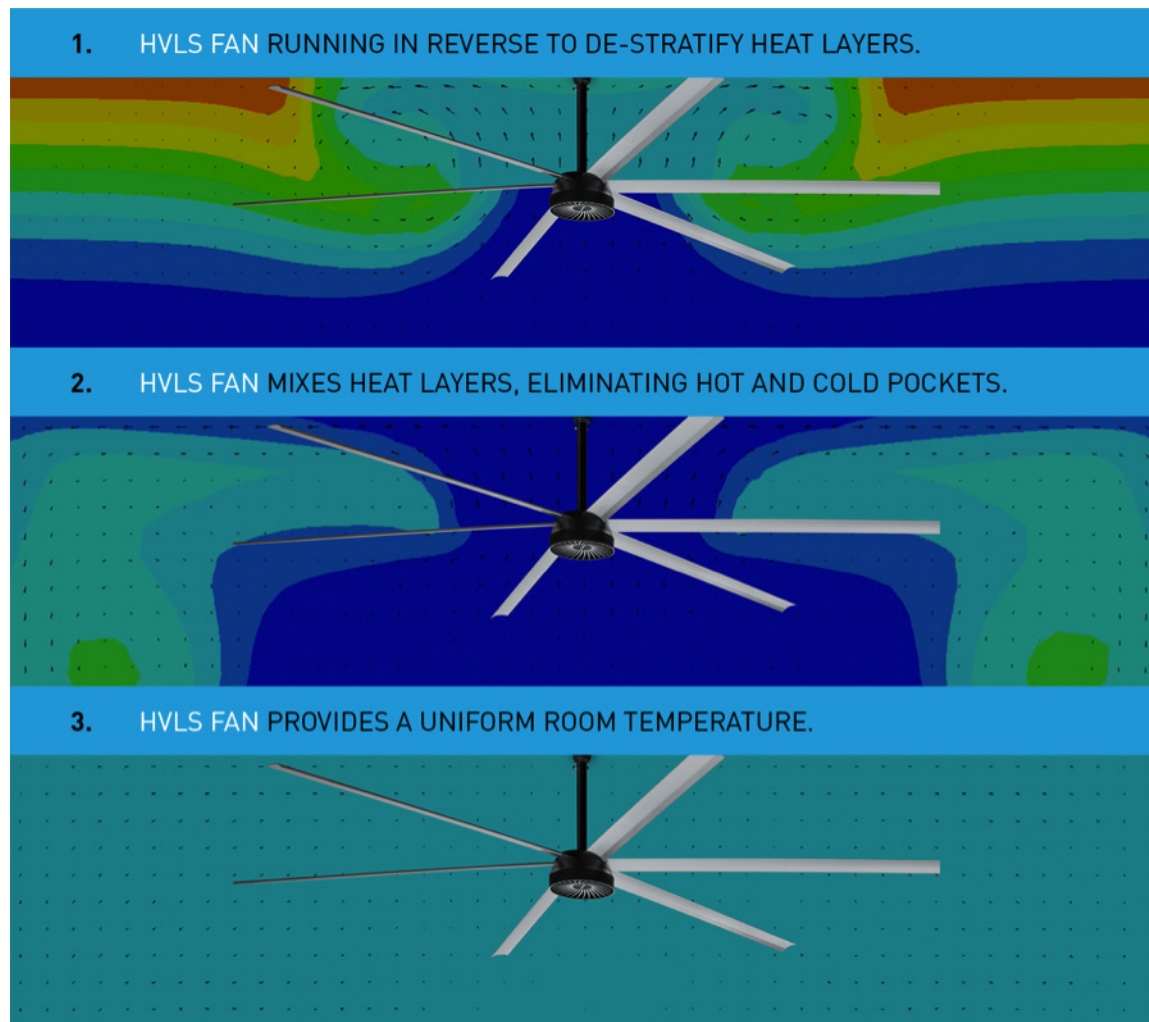

## Three Factors that Affect Air Displacement

Effectively mixing large volumes of air may seem as simple as specifying a fan with a high enough CFM. However, there are other factors that strongly affect air displacement.

### 1) Air Column Size

- Longer blades create a wider column of air.
- Large columns of air travel farther than smaller columns. A large column has proportionately less periphery and therefore less drag because the friction between moving air and stationary air occurs at the periphery of the moving column. The air column from a 3-foot diameter fan has more than 6 times as much drag per cubic foot as the air column from a 20-foot diameter fan.
- HVLS fans produce more air movement that travels farther than smaller fans.

### 2) Horizontal Floor Jet

- The movement of air away from the downward air column is called the “horizontal floor jet.”
- The longer the fan blade, the deeper the horizontal floor jet will be.
- HVLS fans have a large downward air column and a deep horizontal floor jet that impacts all areas adjacent to the downward air column.

### 3) Obstructions

- Obstructions such as pallet racks or room dividers act as airflow barriers and prevent air circulation.
- Smaller fans with weak air columns are particularly hindered by obstructions.
- HVLS fans have a large diameter of downward air that washes over and around obstructions.

## Project Solutions

When considering an HVLS fan, it is important to first determine the overall goals for the project. Some common goals are:

- Comfort
- Energy Efficiency
- Health and Wellness

### Comfort

Temperature and humidity are critical components of occupancy comfort. As discussed, uncomfortable workplaces result in reduced productivity, increased errors, and employee complaints. The air circulation from an HVLS fan provides a cooling breeze and moderates humidity in the summer. During the winter months, the rotation of the blades is reversed so that air is pushed up where it mixes with the warm air trapped near the ceiling resulting in a warmer work environment.

### Energy Efficiency

Energy efficiency is now top-of-mind. We see this in the focus on LEED certification and “Green Buildings”. When evaluating a ceiling fan, its energy efficiency can be an important element in the product selection process.

**There are two main ways to evaluate the energy efficiency of a fan:**

- 1) Ratio of air moved to energy used, and
- 2) Reduced energy consumption of an HVAC system when paired with an HVLS fan.

The common method for determining the energy efficiency of a fan is to examine the amount of energy the unit uses in relation to the amount of air it circulates. The ratio is often evaluated by comparing the air moved (measured in CFM) to the energy used (purchased in kilowatt hours). The greater the CFM per kilowatt ratio, the less electricity it takes to move air within the room.

This comparison becomes especially important when designing air circulation strategies for large warehouse spaces. Assume a warehouse is 50 feet wide by 100 feet long with 20-foot ceilings. There are 100,000 cubic feet of air in the space. To circulate the entire volume of air using traditional high-speed fans would require thirteen total fans, as opposed to a single 14-foot HVLS fan. Running all thirteen traditional fans for a day would require 11 kilowatt hours of electricity, where the single HVLS fan would only require 7 kWh. At the current cost of electricity (\$0.12 per kWh), it would cost \$347.00 a year to use the traditional fans and only \$222.00 to use the HVLS fan—a savings of 36%.

To measure the reduced energy consumption of an HVAC system when paired with an HVLS fan, compare kWh used per day without the fan to kWh used per day with the fan. Adding an HVLS fan to support an HVAC system often results in a 20% reduction in kWh usage because the thermostat can be set 3-5° higher (summer) or 3-5° lower (winter).

[Valencia Airport saved \\$66,000 a year - see the case study here](#)

## Health and Wellness

There are two syndromes that can occur if a building has inadequate airflow: Sick Building Syndrome and Sweating Slab Syndrome. Sick Building Syndrome occurs when pollutants and/or toxins build up inside a building and cause the occupants to experience symptoms such as dizziness, nausea, and coughing. Running in reverse, an HVLS fan can pull the fumes up to the exhaust fans removing the pollutants from the building.

[See how HVLS fans reduce your risk of Sick Building Syndrome](#)

Sweating Slab Syndrome impacts humid environments. When air becomes saturated with water (dew point) it deposits moisture on surrounding surfaces, making them slick and therefore dangerous for building occupants and equipment. HVLS fans moderate humidity levels by circulating the air and preventing saturated air from depositing moisture on floors, equipment, and inventory.

[Learn more about preventing Sweating Slab Syndrome](#)

## Selecting an HVLS Fan

HVLS fans are ideal for public spaces like airports, gymnasiums, auto dealerships, shopping malls, and arenas. The key to maximizing the benefit of the HVLS fan is choosing the best product design, the correct size and number of fans, and placing them properly in the space.

### 1. Product Design

**Direct Drive Motor:** HVLS fans at the top of the industry have direct drive motors. Direct drive motors eliminate the gearbox and all its associated problems including noise, weight, and multiple moving parts.

[Learn more about direct drive](#)

**On-Board Processor:** HVLS fans with on-board processors eliminate the need for Variable Frequency Drives (VFD). VFDs are difficult to install because they create electromagnetic interference (EMI) and require precise spacing and unsightly cabling. EMI can disrupt electronic systems and harm computers, networks, and security systems so it is best to remove this complication in specifications.

[Learn more about EMI](#)

**Controller:** Not all manufacturers offer the same capabilities and programming options from their controller so it is important to consider the occupants' control needs when selecting an HVLS fan. If the client wants to easily adjust the speed of the fan, reverse the fan direction in the cooler months, or program run times, it is best to choose a controller with these options. Some

controllers also allow the fans to be “daisy chained” allowing occupants to adjust multiple fans from one controller.

Ensuring the control interface is simple, intuitive, and accessible will encourage the occupants to actively engage in the climate control features of the design project. This will help reduce energy costs over time as the occupants alter the fan speed and not the HVAC system.

## 2. Size and Number

The number of fans needed in a particular space depends on many things including the building’s total volume of air, shape, building material, occupied use, and intended HVLS solution. Because choosing the correct fan(s) for an application is complex, it is best to consult the HVLS manufacturer and request an airflow simulation. However, the table below provides a general fans to space comparison for your information. **See fans-to-space chart and diagram below.**

<i>HVLS Fan Diameter</i>	<i>Coverage Radius</i>	<i>Space between Fans</i>	<i>Minimum Space from Wall</i>
<i>8 foot</i>	<i>30 feet</i>	<i>60 feet</i>	<i>12 feet</i>
<i>12 foot</i>	<i>35 feet</i>	<i>70 feet</i>	<i>18 feet</i>
<i>16 foot</i>	<i>45 feet</i>	<i>90 feet</i>	<i>24 feet</i>
<i>20 foot</i>	<i>52.5 feet</i>	<i>105 feet</i>	<i>30 feet</i>
<i>24 foot</i>	<i>57.5 feet</i>	<i>115 feet</i>	<i>36 feet</i>

**MacroAir**  
engineers of air™

8 foot HVLS fan

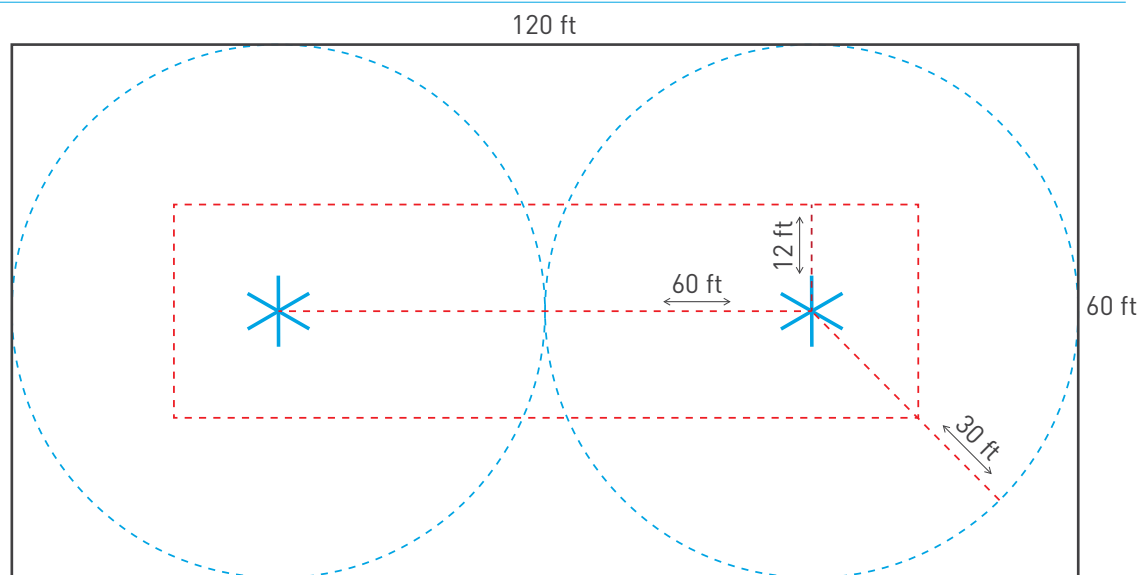

This diagram shows the proper spacing for two 8-foot HVLS fans. The fans are 60 feet apart. The smaller rectangle shows the minimum space required for an 8-foot HVLS fan (12 feet from the wall) and the large rectangle shows the maximum coverage radius.

Note: The diagram above represents the principles of spacing and acts as a simplification of how to properly space your HLVS fans. For detailed product and placement recommendations contact an HVLS manufacturer or distributor.

### 3. Proper Placement

Positioning the fans to overcome ground obstructions is important to ensure full de-stratification of the space. If the obstruction is a single object, like a large piece of stationary equipment, the HVLS fan should be centered above the object whenever possible so that the air column can wash over the obstruction. If there are a series of obstacles, place the fans between the obstructions to allow the full column of air to fall directly to the floor. Because every building design is different, it is best to consult the HVLS manufacturer for installation placement recommendations.

#### Summary

Architects gain more control over air circulation when HVLS fans are included in the climate control strategy. Specifying HVLS fans help the building occupants enjoy better air quality and efficient temperature control.

**Gearless: The MacroAir Difference**

Greater Savings, More Efficiently  
with Direct Drive Technology



[Download PDF >](#)

**Contact a MacroAir Distributor**

Get all your questions answered  
and start saving energy today.



[Contact Us >](#)