

MODBUS is the most popular industrial protocol being used today, for good reasons. It is simple, inexpensive, universal and easy to use. Even though MODBUS has been around since the past century—nearly 30 years—almost all major industrial instrumentation and automation equipment vendors continue to support it in new products. Although new analyzers, flowmeters and PLCs may have a wireless, Ethernet or fieldbus interface, MODBUS is still the protocol that most vendors choose to implement in new and old devices.

Another advantage of MODBUS is that it can run over virtually all communication media, including twisted pair wires, wireless, fiber optics, Ethernet, telephone modems, cell phones and microwave. This means that a MODBUS connection can be established in a new or existing plant fairly easily. In fact, one growing application for MODBUS is providing digital communications in older plants, using existing twisted pair wiring.

In this white paper, we'll examine how MODBUS works and look at a few clever ways that MODBUS can be used in new and legacy plants.

What is MODBUS?

MODBUS was developed by Modicon (now Schneider Electric) in 1979 as a means for communicating with many devices over a single twisted pair wire. The original scheme ran over RS232, but was adapted to run on RS485 to gain faster speed, longer distances and a true multi-drop network. MODBUS quickly became a de facto standard in the automation industry, and Modicon released it to the public as a royalty free protocol.

Today, MODBUS-IDA (www.MODBUS.org), the largest organized group of MODBUS users and vendors, continues to support the MODBUS protocol worldwide.

MODBUS is a “master-slave” system, where the “master” communicates with one or multiple “slaves.” The master typically is a PLC (Programmable Logic Controller), PC, DCS (Distributed Control System) or RTU (Remote Terminal Unit). MODBUS RTU slaves are often field devices, all of which connect to the network in a multi-drop configuration, Figure 1. When a MODBUS RTU master wants information from a device, the master sends a message that contains the device’s address, data it wants, and a checksum for error detection. Every other device on the network sees the message, but only the device that is addressed responds.

Figure 1. A MODBUS RTU network consists of one “master,” such as a PLC or DCS, and up to 247 “slave” devices connected in a multi-drop configuration.

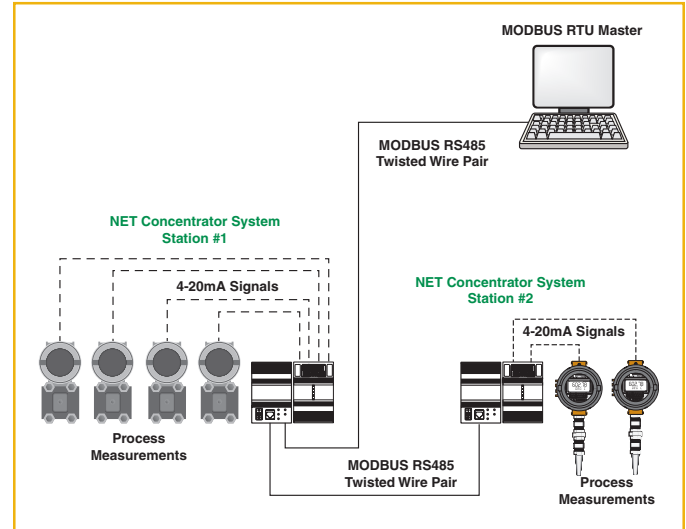

Slave devices on MODBUS networks cannot initiate communication; they can only respond. In other words, they speak only when spoken to. Some manufacturers are developing “hybrid” devices that act as MODBUS slaves, but also have “write capability,” thus making them pseudo-Masters at times.

The three most common MODBUS versions used today are:

- MODBUS ASCII
- MODBUS RTU
- MODBUS/TCP

All MODBUS messages are sent in the same format. The only difference among the three MODBUS types is in how the messages are coded.

In MODBUS ASCII, all messages are coded in hexadecimal, using 4-bit ASCII characters. For every byte of information, two communication bytes are needed, twice as many as with MODBUS RTU or MODBUS/TCP. Therefore, MODBUS ASCII is the slowest of the three protocols, but is suitable when telephone modem or radio (RF) links are used. This is because ASCII uses characters to delimit a message. Because of this delimiting of the message, any delays in the transmission medium will not cause the message to be misinterpreted by the receiving device. This can be important when dealing with slow modems, cell phones, noisy connections, or other difficult transmission mediums.

Using MODBUS for Process Control and Automation

In MODBUS RTU, data is coded in binary, and requires only one communication byte per data byte. This is ideal for use over RS232 or multi-drop RS485 networks, at speeds from 1,200 to 115Kbaud. The most common speeds are 9,600 and 19,200 baud. MODBUS RTU is the most widely used industrial protocol, so most of this paper will focus on MODBUS RTU basics and application considerations.

MODBUS/TCP is simply MODBUS over Ethernet. Instead of using device addresses to communicate with slave devices, IP addresses are used. With MODBUS/TCP, the MODBUS data is simply encapsulated inside a TCP/IP packet. Hence, any Ethernet network that supports TCP/IP should immediately support MODBUS/TCP. More details regarding this version of MODBUS will be covered in a later section entitled “MODBUS Over Ethernet.”

MODBUS RTU Basics

To communicate with a slave device, the master sends a message containing:

- Device Address
- Function Code
- Data
- Error Check

The *Device Address* is a number from 0 to 247. Messages sent to address 0 (broadcast messages) can be accepted by all slaves, but numbers 1-247 are addresses of specific devices. With the exception of broadcast messages, a slave device always responds to a MODBUS message so the master knows the message was received.

The *Function Code* defines the command that the slave device is to execute, such as read data, accept data, report status, etc. (Figure 2). Function codes are 1 to 255. Some function codes have sub-function codes.

The *Data* defines addresses in the device’s memory map for read functions, contains data values to be written into the device’s memory, or contains other information needed to carry out the function requested.

The *Error Check* is a 16-bit numeric value representing the Cyclic Redundancy Check (CRC). The CRC is generated by the master (via a complex procedure involving ORing and shifting data) and checked by the receiving device. If the CRC values do not match, the device asks for a retransmission of the message. In some systems, a parity check can also be applied.

When the slave device performs the requested function, it sends a message back to the master. The returning message contains the slave’s address and requested function code (so the master knows who is responding), the data requested, and an Error Check value.

MODBUS Memory Map

Each MODBUS device has memory, where process variable data is stored. The MODBUS specification dictates how data is retrieved and what type of data can be retrieved. However, it does not place a limitation on how and where the device vendor maps this data in its memory map. Below would be a common example of how a vendor might logically map different types of process variable data.

Discrete inputs and coils are one-bit values, and each has a specific address. Analog inputs (also called “Input Registers”) are stored in 16-bit registers. By utilizing two of these registers MODBUS can support the IEEE 32-bit floating point format. Holding Registers are also 16-bit internal registers that can support floating point.

Figure 2. Function Codes.

Command	Function Code
01	Read Coils
02	Read Discrete Inputs
03	Read Holding Registers
04	Read Input Registers
05	Write Single Coil
06	Write Single Register
07	Read Exception Status
08	Diagnostics
.	
.	
xx	Up to 255 function codes, depending on the device

Figure 3. The literature or operation manuals of most MODBUS-compatible devices, such as this TMZ Temperature Transmitter from Moore Industries, publish the addresses of key variables in the MODBUS Memory Map. The TMZ’s addresses conform to the MODBUS spec.

Table Addresses	Type	Table Name
1-9999	Read or Write	Coils
10001-19999	Read Only	Discrete Inputs
03	Read Only	Input Registers
04	Read or Write	Holding Registers

Using MODBUS for Process Control and Automation

Data in the memory map is defined in the MODBUS specification. Assuming that the device vendor followed the MODBUS specification (not all do), all data can easily be accessed by the MODBUS master, which follows the specification. In many cases, the device vendor publishes the memory locations (Figure 3), making it easy for the person programming the master to communicate with the slave device.

Reading and Writing Data

MODBUS has up to 255 function codes, but 01 (read coils), 02 (read discrete inputs), 03 (read holding registers) and 04 (read input registers) are the most commonly used read functions that used to collect data from

MODBUS slaves. For example, to read three 16-bit words of analog data from device 5's memory map, the master sends a command that looks something like this:

5 04 2 3 CRC

Where 5 is the device address, 04 says to read input registers, 2 is the starting address (address 30,002), 3 means to read three contiguous data values starting at address 30,002, and CRC is the error check value for this message. The slave device, upon receiving this command, sends back a response that looks something like this:

5 04 aa bb cc CRC

Figure 4. Home Run Wiring vs MODBUS. In most plants, field instruments connect to the control system with individual "home run" twisted pairs (below). When the instruments are wired into a distributed I/O system, such as the NCS from Moore Industries (center), more devices can be added, but only a single twisted pair is needed to transmit all the data to the MODBUS master. Multiple NCS systems can be networked (bottom) over the same MODBUS network, so the entire plant can be converted from home run wiring to MODBUS.

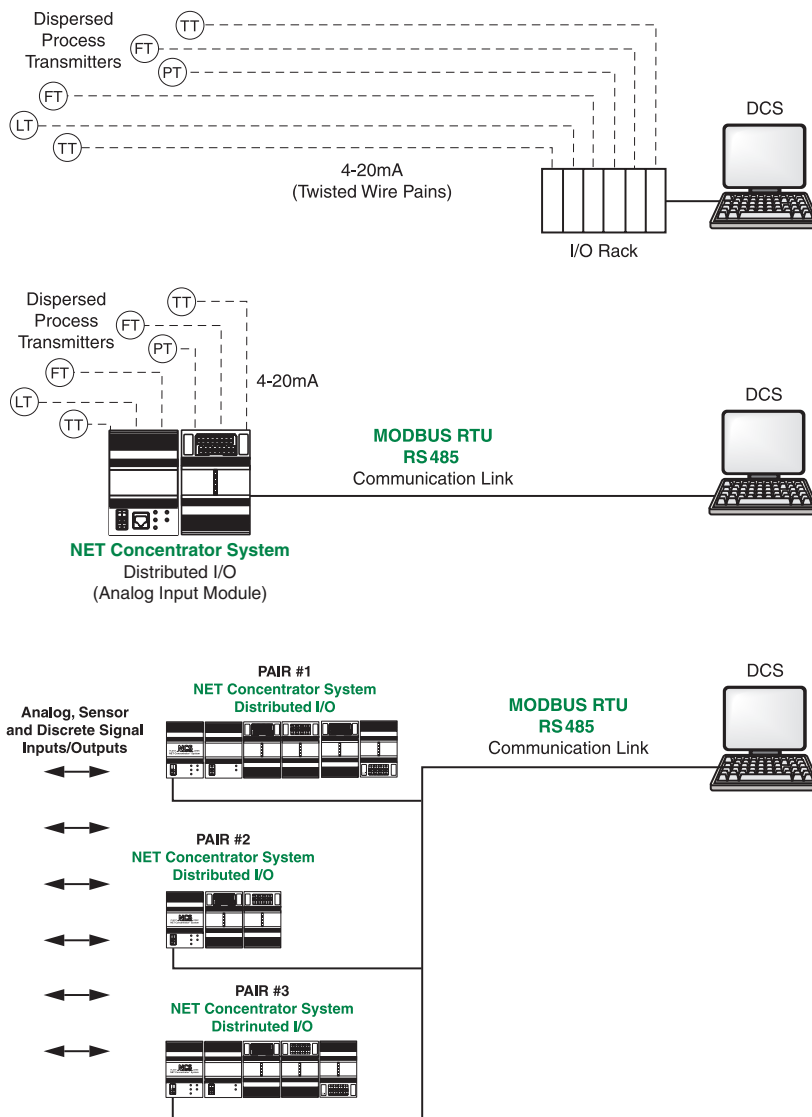

Using MODBUS for Process Control and Automation

Where 5 is the device's address; 04 is the repeated read command; aa, bb and cc are the three 16-bit data values; and CRC is the error check value for this message.

Reading and writing digital inputs and outputs is done in a similar manner using different read and write functions.

Assuming that the device follows the MODBUS specification, it is a simple programming task to set up the master to read and write data, check status, obtain diagnostic information and perform various control and monitoring functions.

Connecting MODBUS Devices

One of the easiest ways to bring field devices into a process control system, PLC or industrial computer is to simply connect digital and analog I/O into a distributed I/O system that has MODBUS communication capability. For example, the NCS (Net Concentrator System) from Moore Industries allows a user to connect analog and digital signals remotely, which can then be connected to a MODBUS master via twisted pair cable. Multiple NCS systems can be installed in several locations throughout the plant, all linked by MODBUS (Figure 4).

This solution works for both new and existing plants. In many existing plants, field instruments typically connect to the DCS or PLC via "home run wiring," where each device is connected with individual twisted pairs that carry analog signals. With the NCS, one of those twisted pairs can be used for the MODBUS signal. This is particularly useful if the plant wants to add additional field instruments, but does not want to run more wiring (at an

installed cost of \$100 per foot). A distributed I/O system can accommodate all of the existing I/O, or it can be used just to send data from all the new field instruments.

In some cases, the control system is not able to deal with a MODBUS signal. It may be that the legacy control system is accustomed to dealing with 4-20mA analog I/O and directly wired digital I/O, and reprogramming the old system to accommodate MODBUS data would be difficult. Often, users would like to add new remote signals to their system without having to run wire or buy expensive MODBUS interface cards that require extensive re-programming. In that case, a peer to peer solution works best. For example, the CCS (Cable Concentrator System) and the NCS (Net Concentrator System) from Moore Industries both have peer-to-peer communication abilities.

The NCS and CCS are similar to a distributed I/O module, but have more built-in intelligence and can be set up in either a peer-to-peer or peer-to-host configuration.

With a peer-to-peer NCS system (Figure 5), two concentrators are used: one in the field and one in the control room. Field instruments connect to the remote NCS, which connects to the control room NCS via a single twisted pair wire. Then, outputs from the control room NCS are wired into the control system's existing analog I/O panel. In this way, the analog signals from the new field transmitters can be seen in their original analog state through the plant's existing analog I/O cards. This makes programming and commissioning of the new signals less difficult than programming new digital interface cards. These peer-to-peer solutions can also accommodate bi-directional

Figure 5. Peer to Peer Wiring. In some cases, the control system is not able to deal with a Modbus signal. In that case, a peer-to-peer solution with dual NCS devices simply replaces all the home run wiring with a single MODBUS cable. Analog outputs from the second NCS are then wired directly into the control system's I/O panel.

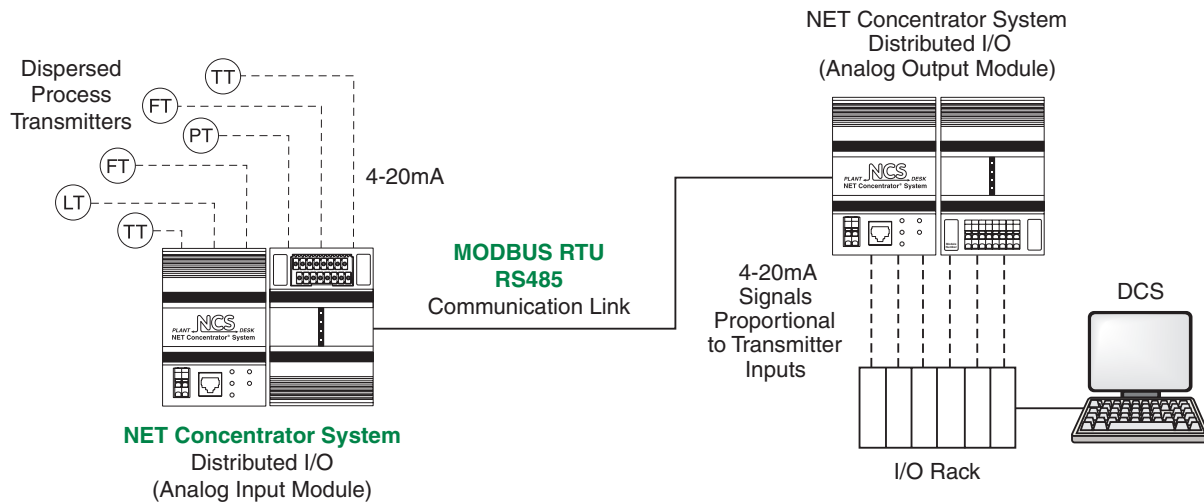

Using MODBUS for Process Control and Automation

communication in which both sides of the system can have inputs and outputs.

HART via MODBUS

Another challenge for legacy plants is to find an inexpensive and convenient way to take advantage of installed and “to be installed” HART smart devices. HART stands for Highway Addressable Remote Transducer. HART is a digital protocol that was designed to allow transmitters to simultaneously transmit digital data and an analog signal over traditional plant installed copper twisted pair. This enabled users to configure, interrogate and diagnose transmitters locally or remotely via any point along the twisted pair. HART slaves can be wired in a point-to-point configuration or in a multi-drop configuration. In the point-to-point configuration, which is the most common, the HART transmitter varies the current on the analog loop to represent the desired process variable. While it is possible to monitor the digital HART data only, in a point-to-point configuration, it is rarely done. As the transmitter controls the current, it also has the ability to send multiple digital pieces of information via the HART data stream. Both process variable data and digital data can be transmitted by the HART slave or transmitter. This data could be used to monitor the health of instruments or can be used by the process control system or asset management system to optimize processes, assist in providing tighter control, or prevent unexpected process hiccups. In some cases, existing plants may have hundreds of HART-enabled instruments. Unfortunately, for one reason or another, many plants never exploited the capabilities of HART.

In today’s world of asset management, remote diagnostics and advanced control, many plants would like to extract that digital information, but their control system and existing wiring can’t accommodate it. The control system may not be set up to extract HART data from the digital signal or, as above, the control system only wants to see hardwired digital and analog I/O. A HART instrument can send up to four process variables via the HART signal: PV (Primary Variable), SV (Secondary Variable), TV (Tertiary Variable) and FV (Fourth Variable). Additionally, there are various bits and bytes of status data that can also be transmitted. However, if the control system cannot read the additional process variable data – or any of the other diagnostic and status information—from the digital HART signal, then that data goes to waste.

Customers certainly have options to get this HART data, even in legacy and mature plants. Some DCS companies offer new upgraded analog I/O cards that have the ability to “pick off” this HART data. However, these cards usually cost three to five times as much as the traditional analog

I/O cards. Additionally, there are HART mux bricks that can be installed on existing analog loops that have RS422 and RS485 outputs to asset management systems or DCSes. Again, these I/O mux bricks can be cost prohibitive. An optional route, using a HART to MODBUS converter like the HIM (HART Interface Module) from Moore Industries, is cost effective and allows the flexibility of monitoring just a few or many loops at reasonable costs.

Figure 6. A HART Interface Module (HIM) extracts digital data from the HART signal and stores it in its MODBUS memory map, so that any MODBUS master can read it. The original 4-20mA signal is still wired to the control system as before.

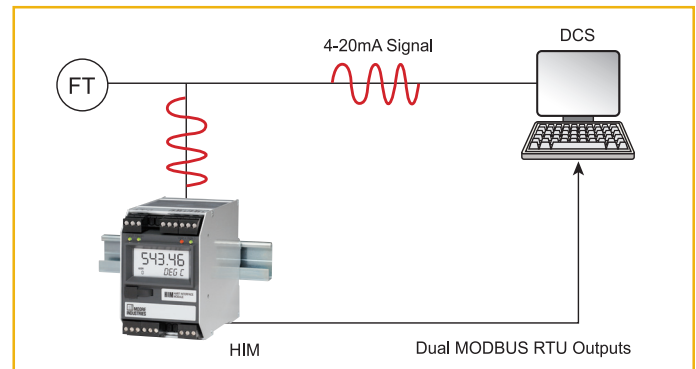

With a HART interface module that supports MODBUS RTU communication, all the HART data can be brought to the control system simply and cost effectively (Figure 6). The HIM is a smart device that acts like HART master on the front end and MODBUS RTU slave on the back end. The HIM extracts all the HART data from the transmitter’s analog signal without compromising or interfering with the 4-20mA signal going to the control system. It then provides a display, three 4-20mA signals, two relays and an optional dual MODBUS RTU output. When the MODBUS option is utilized, the HART data is digitally mapped to the HIM’s MODBUS memory map where it can then be polled by a PLC or DCS that is acting as the MODBUS RTU Master. By multi-dropping various HIM devices via RS485, this essentially becomes a scaled-down asset management system for a fraction of the cost.

Wireless MODBUS

A MODBUS network can be set up fairly easily to work over a wireless link (Figure 7). Essentially, all the wireless link does is replace the twisted pair cables with a transmitter/receiver at each end of the network. Many wireless radio manufacturers support the MODBUS protocol. However, due to some encryption schemes and time delays that radios and modems use, it is important to consult with your wireless vendor before making the assumption that it is supported.

Using MODBUS for Process Control and Automation

Obviously the major advantage of wireless MODBUS is the cost savings in wiring infrastructure. Signals that are needed from tank farms, well heads, and various other remote locations have historically been cost prohibitive to monitor and control.

Fortunately, MODBUS via wireless is transparent to the control system or host and the slave. Like the systems described above for legacy plants, the host system doesn't even know that a wireless MODBUS network exists, because it doesn't have to deal with it. When a MODBUS master makes a request to a slave and the packets arrive at the transmitting radio, it will usually re-order the packets and encrypt them before transmission. Once the RF (Radio Frequency) packets are received by the "slave" radio, it de-encrypts them and puts them back in order to represent a valid MODBUS Packet. Assuming

trum noise analysis can often avoid many communication hiccups.

MODBUS over Ethernet

MODBUS/TCP is often referred to as MODBUS over Ethernet. For the most part, MODBUS/TCP is simply MODBUS packets encapsulated in standard TCP/IP packets. This enables MODBUS/TCP devices to immediately and easily connect and communicate over existing Ethernet and fiber networks. MODBUS/TCP also allows many more addresses than RS485, the use of multiple Masters, and speeds in the gigabit range. While MODBUS RTU has a limitation of 247 nodes per network, MODBUS/TCP networks can have as many slaves as the physical layer can handle. Often this number is somewhere around 1,024. Ethernet's rapid adoption within the process control and automation industry has allowed MODBUS/TCP to become the most widely used, fastest growing and supported industrial protocol over Ethernet.

Figure 7. A wireless interface, such as the Wireless Link Module from Moore Industries, replaces the twisted pair with an RF link.

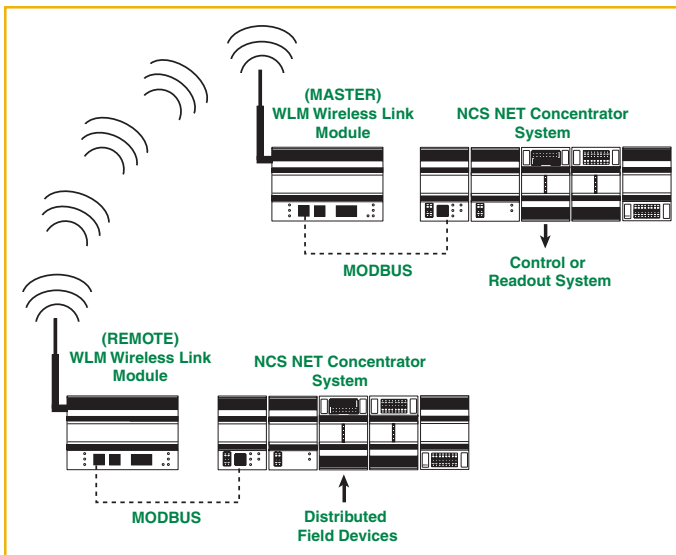

Although PLC vendors of all sizes have adopted their own proprietary protocols over Ethernet, almost all of them support MODBUS/TCP. And for those PLC vendors who don't currently support MODBUS/TCP, there are many companies like Prosoft Technologies and SST that offer chassis-style slide in MODBUS/TCP communication cards and stand alone gateways.

Another advantage of MODBUS/TCP is its ability to have multiple masters. Unlike MODBUS RTU and MODBUS ASCII, MODBUS/TCP will allow multiple masters to poll the same slave device simultaneously. This is allowed because, over Ethernet using TCP/IP, multiple messages can be sent, buffered and delivered without the requirement of token passing or total bus control, which is often the case with many RS485 and RS422 protocols.

that the packet has not been damaged or corrupted, it will then be sent to the destined slave. The slave will respond back to the Master and the process starts again.

Sometimes it is important to pay special attention to a MODBUS communication parameter called "timeout." Timeout is the amount of time that the MODBUS master will wait for a response from a slave before attempting a re-transmission. Depending on how well the radio is communicating, packets can be delayed, causing an unnecessary amount of retries and re-transmits. With today's FHSS (Frequency Hopping Spread Spectrum) radios, most of these parameters can be massaged for efficient transfer of MODBUS packets. However, proper radio site surveys that include signal strength and spec-

Putting Control in the Field with MODBUS

So far, we've only dealt with simple MODBUS data acquisition systems. It is also possible to install control devices in the field that will communicate to the central control system via MODBUS. The NCS, mentioned above as a concentrator, also has a powerful CPU (Central Processing unit) and real time control kernel that can be programmed to perform control functions, such as PID, on/off control, local alarming, complex math equations diagnostics and alarm monitoring.

Because it has PLC-type logic, PID-type control functions, and advanced computing capabilities, an NCS can often eliminate the need for a PLC, industrial computer, or a small DCS for a fraction of the price. While the MODBUS protocol doesn't have the capabilities of other

Using MODBUS for Process Control and Automation

protocols like FOUNDATION Fieldbus and CIP (Common Industrial Protocol) it does often fit the need for many applications where local control is desired, and remote monitoring and supervisory control via Ethernet is the most cost effective and convenient solution available.

Another “smart” and control capable MODBUS device, the MDS Equation Station from Moore Industries, is a multi-function controller that is able to perform a wide variety of control functions and calculations. It eliminates the need for a PLC or large controller for simple, multivariable control tasks, such as monitoring and controlling pulp levels in a digester, or performing mass flow calculations using inputs from various flow, temperature and pressure transmitters. Up to 127 MDS modules can be installed on a single MODBUS network to control or collect signals from around the plant.

PID (Proportional, Integral and Derivative) controllers were originally standalone non-communicating controllers. As PLCs and DCSes got smarter, so did the controllers. Today, many end users still prefer the direct readout and simple to program style of the single loop controller. Digital communication protocols like MODBUS may have added a little more life to these once standalone instruments. By multi-dropping controllers you can now create your own small distributed control system, Figure 8.

MODBUS: The Universal Interface

While the modern control world continues to grapple with advanced concepts such as fieldbus and mesh networks, the simplicity of MODBUS and its ease of implementation over so many communication media continues to allow it to be the most widely supported and implemented industrial protocol in the world. When users of existing legacy control systems discover the need to expand field instrumentation or add remote controllers, they very often turn to MODBUS as a simple solution to complex problems. When users try to connect an exotic device to a control system, using the device’s MODBUS interface often proves to be easiest method. Although MODBUS is one of the oldest communication methods, it is also the most popular—for very good reasons. It’s easy to use, reliable, inexpensive, and connects to almost every sensing and control device in the control industry.

Figure 8. MODBUS-capable devices, such as the 1/4 DIN 545 Dual Loop PID controller, can put control functions in the field. Multi-dropping the MODBUS output and sending it to a Windows based SCADA package creates a small distributed control system.

